

DESIGN VARIANTS – GEA HILGE CONTRA

Standard variants	Description
GEA Hilge CONTRA Adapta	Close-coupled pump with bearing bracket and coupling, horizontal installation
GEA Hilge CONTRA Adapta-SUPER	Close-coupled pump with bearing bracket and coupling, horizontal installation, motor with stainless steel shroud
GEA Hilge CONTRA Adapta-V	Close-coupled pump with bearing bracket and coupling, vertical installation
GEA Hilge CONTRA Bloc	Close-coupled pump, horizontal installation
GEA Hilge CONTRA Bloc-SUPER	Close-coupled pump, horizontal installation, motor with stainless steel shroud
GEA Hilge CONTRA Bloc-V	Close-coupled pump, vertical installation
Variations upon request	Description
GEA Hilge CONTRA tronic	Horizontal/vertical installation, motor with built-in frequency converter (up to 18.5 kW)

TECHNICAL DATA

GEA Hilge CONTRA	50 Hz	60 Hz
Flow	40 m ³ /h	35 m ³ /h
Head	160 m	230 m
Liquid temperature	up to 95 °C, 150 °C (SIP)	
Operating pressure	PN 25	

PERFORMANCE CURVE
50 HZ

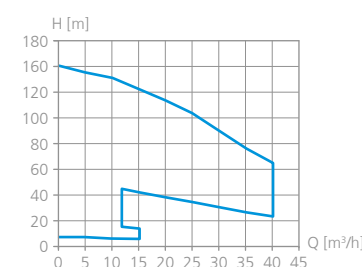

PERFORMANCE CURVE
60 HZ

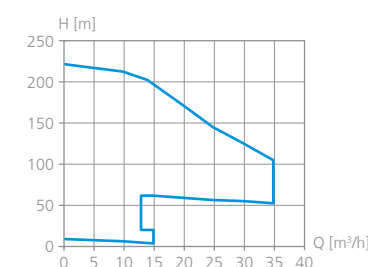

We live our values.

Excellence • Passion • Integrity • Responsibility • GEA-versity

GEA Group is a global engineering company with multi-billion euro sales and operations in more than 50 countries. Founded in 1881, the company is one of the largest providers of innovative equipment and process technology. GEA Group is listed in the STOXX® Europe 600 Index.

GEA Germany
GEA Hilge GmbH & Co. KG
Hilgestraße 37–47
55294 Bodenheim, Germany

Tel +49 6135 7016-0
Fax +49 6135 1737

info@gea.com
gea.com

GEA VARIPUMP



GEA Hilge CONTRA

Single- and Multi-Stage Pumps
for Advanced Applications



Certified Safe Performance for your Demanding Processes

The GEA Hilge CONTRA range in the GEA VARIPUMP line offers single or multi-stage, end-suction centrifugal pumps designed in accordance with the Qualified Hygienic Design (QHD) criteria and with EHEDG certification.

The pumps are CIP- and SIP-capable according to DIN EN 12462, meeting the world's highest hygiene standards. Apart from DIN, ASME and ANSI connections, a flexible range of custom connections is available upon request.

The pumps, furthermore, meet GMP requirements and use FDA-approved materials.

High Quality Throughout

The pumps are constructed with the use of deep-drawn and/or forged stainless steel materials in quality 1.4404 and 1.4435 (equivalent to AISI 316L), which guarantee a pore and blowhole-free surface, as opposed to cast material.

The GEA Hilge CONTRA range pumps have open impellers, the multi-stages pumps also have open diffusers. The O-ring seal locations for the casing and impellers meet hygienic design criteria with metal-to-metal contact seal areas and no pump casing dead ends. The vertical versions of the GEA Hilge CONTRA pumps are fully self-draining through the suction port.

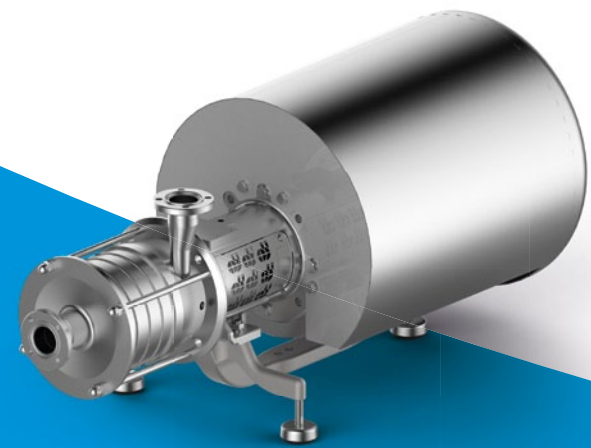

GEA Hilge CONTRA Adapta-SUPER



FEATURES AND BENEFITS

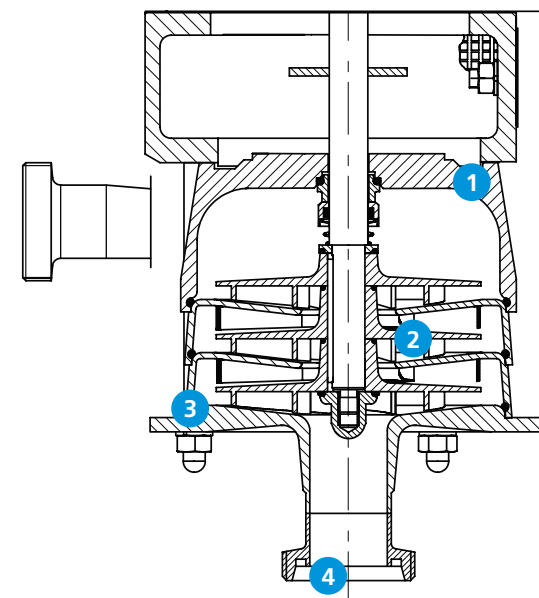

1 No dead ends

The pumps comply with most stringent hygienic demands to prevent contamination

2 All wetted parts are electro-polished

High corrosion resistance and surface finish

3 Fully drainable

Quick and easy cleaning at vertical position

4 Multiple flange options

Easily adaptable in any systems

A Variety of Applications

The GEA Hilge CONTRA pumps offer extremely reliable operation under tough operating conditions. Their hygienic design and the use of pore-free materials make them suitable within:

Food & Beverage

- Dairy
- Carbonising in breweries
- CIP-feeding

Pharmaceutical Industry

- Pumping of pure water (WFI)
- Biotech production
- Infusions (nutrient solutions, alcohol)
- Filling stations

Personal Care

- Soap
- Creme
- Lotions

Industry

- Purification processes (CIP systems)
- Water technology processes
- Semiconductor production
- Metal surface treatment



Certificates and Documents

- Work certificates, e.g. acc. to DIN EN 10204, 2.2 or 3.1
- FDA and EHEDG certificates
- Surface roughness measurement

Shaft Seals – Choose the One to Suit You

A wide range of shaft seal options is available to suit different media and applications. The mechanical seals used in the GEA Hilge CONTRA range are single inboard seals that maintain the optimum position in the liquid.

This ensures lubrication cooling, CIP and SIP in full accordance with the criteria of hygienic design.

Choices Include

- Single mechanical seals in sterile execution
- Double mechanical seals (tandem or back-to-back)
- Standard seal face material: carbon/stainless steel and SiC/SiC
- Standard O-ring material: EPDM (FDA-compliant)
- Additional designs and materials available upon request

Customised Solutions

Customisation is one of the highlights of the GEA Hilge CONTRA pump range. The range of these single and multi-stage sanitary pumps lets you choose between several variants to suit your task.



GEA Hilge CONTRA Adapta vertical